

OWNER'S MANUAL

GROUND TILTERS MODEL BGLT-4000

Contents

Warnings and Safety Instructions	1	Hydraulic Operation and Schematic	7-8
Receiving Instructions	1	Exploded Parts Drawing	9
Loading Instructions	2	Parts Identification	10
Operating Instructions	2	Trouble Shooting Guide	11-12
Installation Instructions	2	Warning Label Identification	13
Periodic Maintenance Instructions	3	Material Safety Data Sheets	14-15
Electric Schematic	7	Warranty	16
Power Conversion	8-9	Service Record	16

WARNINGS & SAFETY INSTRUCTIONS

Read owner's manual completely before operating unit!

- Not a personnel lift.
- Never go under platform if there is weight on unit.
- Remove weight & disconnect power before working on unit.
- Use only maintenance parts supplied or approved by the manufacturer.
- Do not change pressure relief valve setting.
- Do not clamp hydraulic cylinder in a vise as you may distort the barrel.
- Never operate the lift unless you are watching it.
- Load the lift as uniformly as possible.
- Consult the factory for uneven loading.
- Do not continue to operate the UP control if unit is not raising.
- Relieve system pressure by operating the DOWN control after the unit has come to rest.
- Consult factory if adding or performing any modification to the original equipment.
- Do not use brake fluids or jack oils. Use AW 32 Hydraulic oil or equal.
- Make sure all operator safety labels (see p. 16) and guards are in place.

Remove all packing and strapping material, inspect for damage. IF DAMAGE IS EVIDENT, FILE A CLAIM WITH THE CARRIER IMMEDIATELY! Also, check the unit size, type of power unit, etc., to ensure the unit is correct for the intended application.

SERIAL NUMBER AND CAPACITY

The serial number and capacity are inscribed on the nameplate (See p. 16 for location). Please remember to include these numbers in any correspondence with your dealer or the factory.

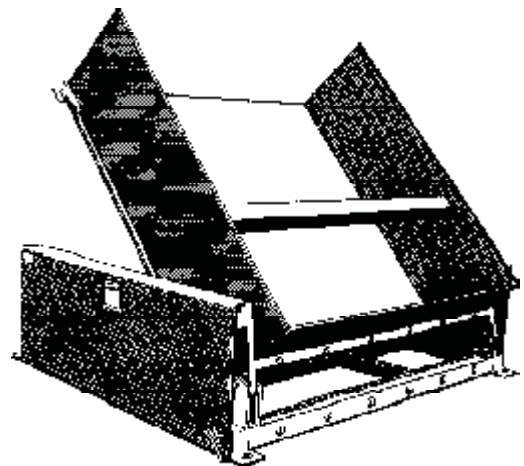

**Ground Lift Tilter
Model BGLT-4000**

RECEIVING INSTRUCTIONS

Every unit is thoroughly tested and inspected prior to shipment. However, it is possible that the unit may incur damage during transit. If you see damage when unloading make a note of it on the SHIPPER RECEIVER.

LOADING INSTRUCTIONS

The load capacity rating as inscribed on the nameplate of your unit designates the net capacity for an evenly distributed load. This capacity must never be exceeded, as permanent damage or injury may result.

When loading the lift always follow these guidelines:

- 1.) Always place the load firmly against the restraint lip.
- 2.) Lower the load *gently* on to the platform.

OPERATING INSTRUCTIONS

The *Ground Tilters* are furnished with a constant pressure hand held push button control as standard equipment. In order to operate the unit, pressure must be maintained on the **UP** or **Down** button to raise or lower the *Ground Tilter*. On releasing either button, the deck will remain in that particular position until the **Up** or **Down** button is depressed again.

RESPONSIBILITIES OF OWNERS/USERS

It is the responsibility of the owner/user for the following:

- 1.) The lift must be inspected and maintained in accordance with the guidelines in this manual.
- 2.) Any lift not in safe operating condition must be removed from service until it is returned to proper operating condition.

Unsafe condition may include, but is not limited to the following : excessive hydraulic or air leakage, missing rollers, pins, or fasteners, any cracked or deformed structural members, cut or frayed hydraulic, electric or air lines, and damaged controls or safety devices.

All repairs and maintenance must be performed by qualified personnel.

- 3.) Lift may only be used by authorized personnel. All lift operators must have read and understood all operating procedures and safety guidelines in this Owner's Manual.
- 4.) Lift must never be overloaded.
- 5.) Operator must ensure that all safety features of the lift are functioning properly before each use..
- 6.) Any modifications to the lift must be approved in writing by the manufacturer.

For additional information refer to ANSI National Standard for Industrial Scissor Lifts (ANSI MH29.1-1994)

INSTALLATION INSTRUCTIONS

Review Complete Owner's Manual Before Commencing Installation.

For installation you will need the following:

- 1.) A fork truck or hoisting means.
- 2.) Lag bolts, masonry drill, masonry bit, wrench for lag bolt, grout, and steel shims.
- 3.) An adequate circuit with the specified voltage, including fuses and disconnect or circuit breakers. Reference NFPA 70 (NEC).
- 4.) Minimize voltage drop by using adequate wire size. Reference NFPA 70 (NEC).

WARNING! ONLY INSTALL LIFT ON A STABLE MOUNTING SURFACE.

Move the lift with straps or forks under frame.

Read all the warning labels on the lift and be sure all of the labels on page 16 are on the lift.

The lift **must** be securely anchored to the floor before use (*Except those that are designed to be portable*).

Check local codes pertaining to your application.

If the power unit is to be mounted externally and has been shipped separately, blow out the connecting hydraulic line with compressed air to be sure it is clear before connecting to the power unit.

Be sure maintenance stop is locked in place before getting under platform.

After anchoring to floor, shim or grout the full length on the frame sides.

The entire length of the frame sides must be supported.

Connect power source as shown in electrical section. You must be a qualified electrician to do the hookup.

Operate lift through a few cycles. Check and add oil if necessary. See oil specification on page 5.

Clean up any debris or spilled oil.

ORDERING REPLACEMENT OR EXTRA PARTS

Our company takes pride in using the finest available parts for our equipment. We are not responsible for equipment failure resulting from the use of unapproved replacement parts. To order replacement or extra parts for your equipment contact Customer Service at the factory. In any correspondence with the factory please include the **Serial Number** which is inscribed on the nameplate of the piece of equipment. Use only the part numbers provided in this Owner's Manual. When ordering parts for AC power units please indicate the motor phase and voltage that the equipment is operating on.

PERIODIC MAINTENANCE INSTRUCTIONS

WARNING! BEFORE PERFORMING ANY MAINTENANCE WORK ALWAYS UNLOAD LIFT AND INSTALL MAINTENANCE SAFETY STOP(S)

(A) Before Each Use Check For The Following :

- 1.) Frayed wires, damaged components
- 2.) Oil leaks
- 3.) Pinched or chafed hoses, loose fittings
- 4.) Structural deformation of platform or frame
- 5.) Unusual noise or binding

Do not use if there are any of the above!

(B) Monthly Inspections

- 1.) Check oil level. Oil should be 1" to 1-1/2" below the top of the tank with the lift in the fully lowered position. Add as necessary.
- 2.) Check for oil leaks. See Trouble Shooting Section and correct as necessary.
- 3.) Check pins and pivot points for wear.
- 4.) Check for worn or damaged hydraulic hoses, electrical components, and cords. Repair as necessary.
- 5.) Check rollers for looseness and wear. See Trouble Shooting.
- 6.) Check retaining rings at load rollers and pins.
- 7.) Check for unusual noise. See Trouble Shooting section.
- 8.) Make sure all warning labels are in place and in good condition.
- 9.) Clean off dirt and debris.

(C) Yearly Inspection

Hydraulic oil should be changed at least once a year, or sooner if the oil darkens or becomes gritty. Flush reservoir before refilling. Presence of water is indicated if the oil turns milky. Recommended oil: AW-32 or H015d hydraulic fluid Dexron Transmission fluid.

All maintenance work must be performed by qualified personnel with training in the repair of electrical and hydraulic components.

ELECTRICAL SCHEMATIC

OVERCURRENT & SHORT-CIRCUIT PROTECTION ARE TO BE PROVIDED BY THE END-USER PER THE NEC (NFPA 70) AND LOCAL CODES.

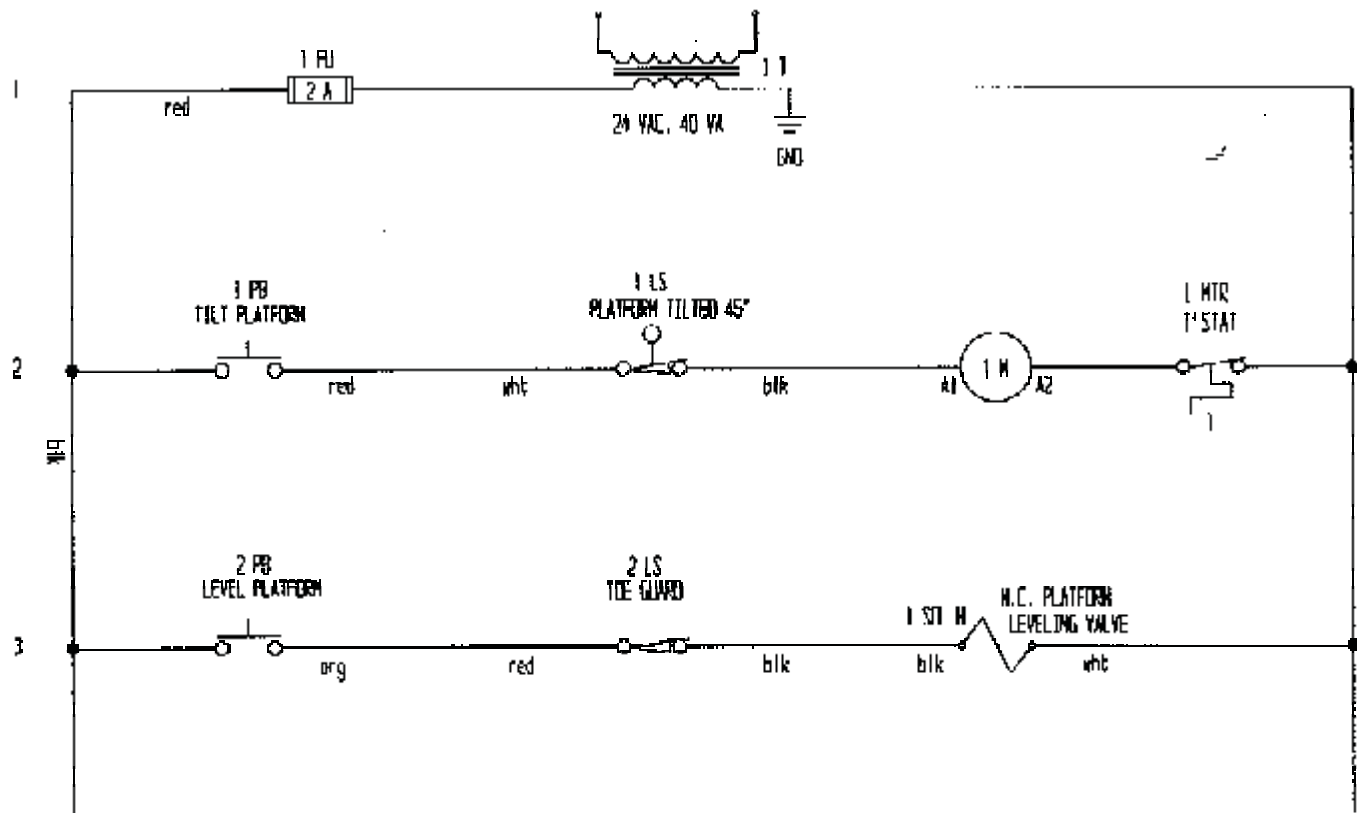

BE SURE ALL POWER IS OFF BEFORE ATTEMPTING TO WORK ON THIS EQUIPMENT!

CAUTION: SERVICE WORK SHOULD BE PERFORMED ONLY BY TRAINED & QUALIFIED PERSONNEL

MOTOR VOLTAGE CONVERSION

MOTOR LEAD CONNECTION DIAGRAM FOR ALL
.5HP, .75HP AND 3HP SINGLE-PHASE MOTORS AND FOR
ALL 2HP, 5.5HP, AND 6.5HP THREE-PHASE MOTORS

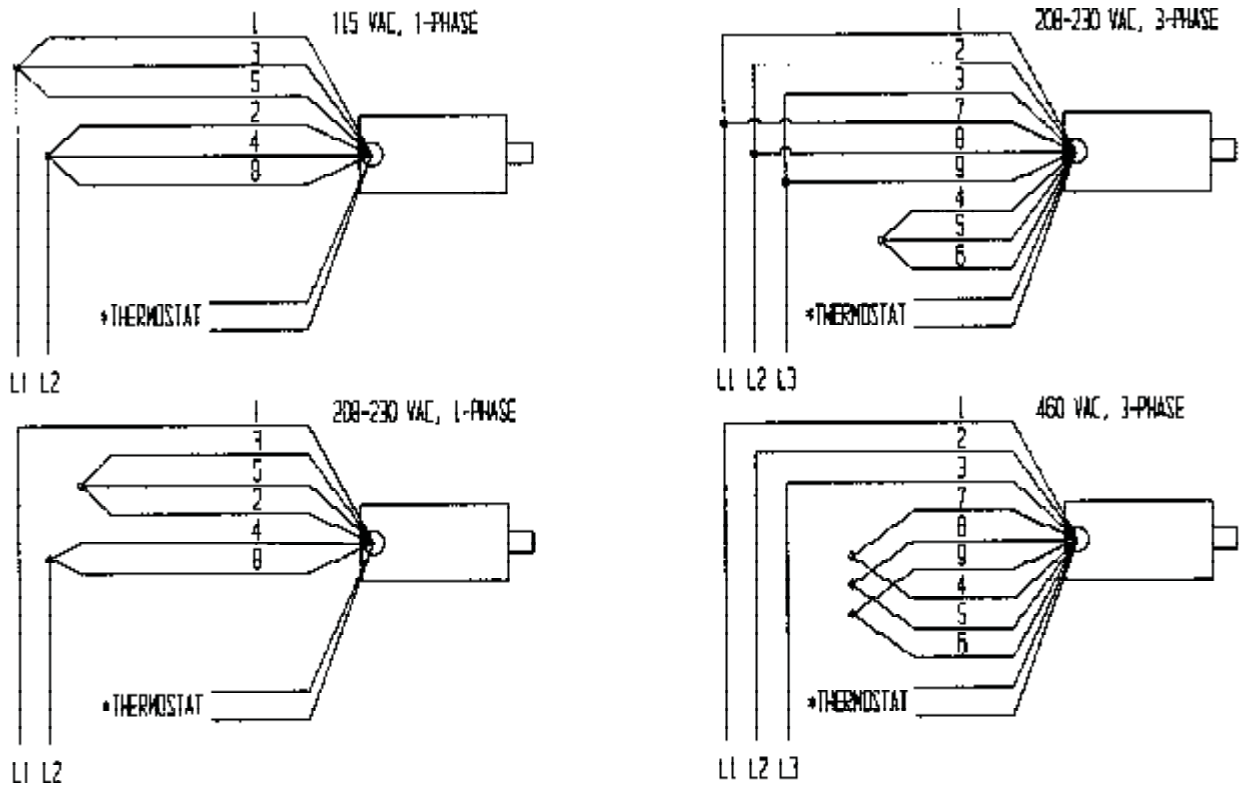

* The two thermostat leads go to: 1) the grounded side of the transformer secondary, and; 2) the motor relay coil, in either order.



BE SURE ALL POWER IS OFF BEFORE ATTEMPTING TO WORK ON THIS EQUIPMENT!

CAUTION: SERVICE WORK SHOULD BE PERFORMED ONLY BY TRAINED & QUALIFIED PERSONNEL

PRIMARY WIRING FOR CONTROL TRANSFORMER

208V, 3-PHASE
FUSING AND
DISCONNECT
TO BE PROVIDED
BY OTHERS

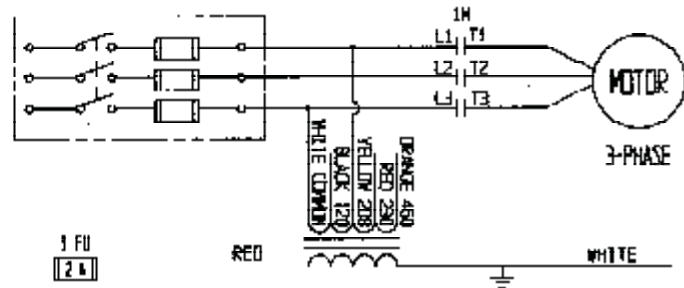

230V, 3-PHASE
FUSING AND
DISCONNECT
TO BE PROVIDED
BY OTHERS

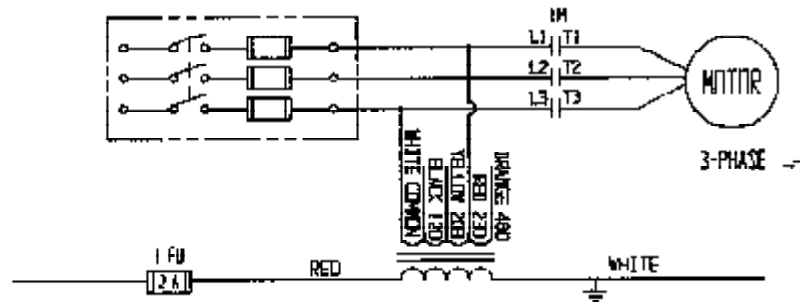

480V, 3-PHASE
FUSING AND
DISCONNECT
TO BE PROVIDED
BY OTHERS

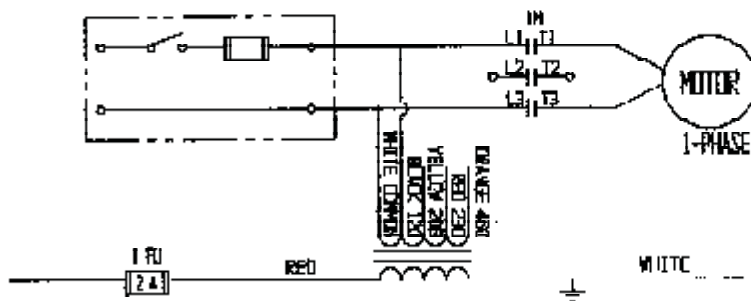
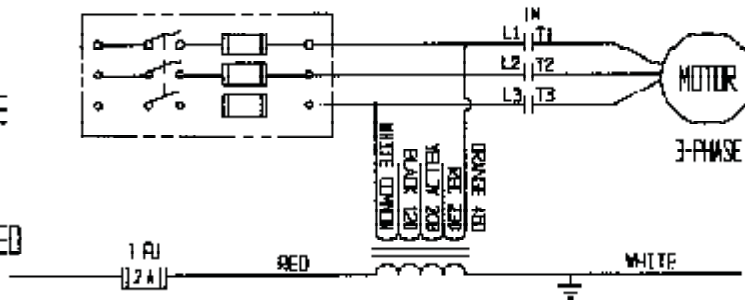

120V, 1-PHASE
FUSING AND
DISCONNECT
TO BE PROVIDED
BY OTHERS

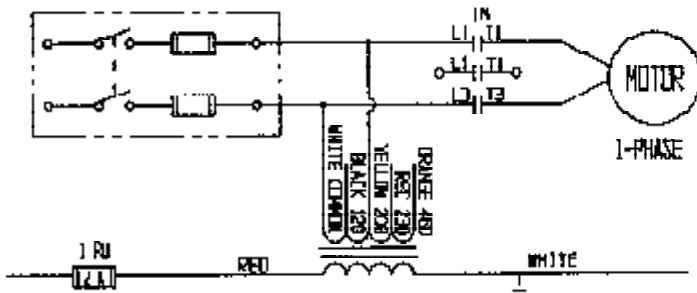

208V, 1-PHASE
FUSING AND
DISCONNECT
TO BE PROVIDED
BY OTHERS

HYDRAULIC OPERATION

When the operator wants to raise the unit, he depresses the **UP** button. This starts the electric motor (Item 3) which turns the hydraulic pump (Item 4). Oil from the reservoir (Item 1) is drawn in through the suction filter (Item 2) and into the pump. The pump delivers the pressurized oil through the check valve (Item 6) before entering the cylinders.

The function of the check valve is to allow the oil to flow in one direction, i.e. towards the cylinders. It also prevents the flow of oil back into the pump circuit when the pump stops running. This holds the oil in the cylinders and maintains the desired elevation.

If the load is excessive, and the **UP** button is still depressed, pressure will build up in the circuit between the pump and the cylinders. This forces the relief valve (Item 5) to unseat allowing the pump flow to return to the reservoir to preventing hydraulic or structural damage.

When the operator desires to lower the units, he depresses the **DOWN** button. This energizes the down solenoid valve (Item 7). The poppet in the solenoid valve is unseated and oil now returns from the cylinders through the return screen (Item 9), solenoid valve, flow control valve (Item 8), oil return hose, and into the reservoir.

The pressure compensated flow control valve (Item 8) controls the down speed of the table. It is preset and cannot be adjusted. Releasing the **DOWN** button will de-energize the solenoid, closing the valve poppet. This prevents the oil from returning to the reservoir and the cylinders will stop retracting. The unit is now maintained at that particular elevation.

CARTRIDGE VALVES

The lowering valve, as discussed above, is of cartridge construction and is virtually maintenance-free. If there is a faulty operation, check Trouble Shooting Section. To clean the cartridge valve, follow this procedure:

- 1.) **WARNING:** remove load and support weight of the table with maintenance stop(s) before removing cartridge valve.
- 2.) Use a sharp object and push poppet in from the bottom to open the valve.
- 3.) Repeat several times while valve is immersed in kerosene or mineral spirits. Blow dry.
- 4.) Blow compressed air through valve while holding open as described in step 2.
- 5.) Inspect "O" rings and the teflon extrusion washer.
- 6.) Reinstall. The valve should be tightened to approximately 30 ft. lbs.

VELOCITY FUSE

There is a brass velocity fuse with a stainless steel spring in the base of each cylinder (Item 10). In the event of a hydraulic hose or fitting failure, the platform starts to lower at a fast rate. As soon as the descent speed exceeds the preset speed, the Velocity Fuse will shut off the oil flow and the platform will remain nearly stationary until pressure is re-applied after repairs are done. This safety feature reduces the possibility of accidental personal injury or damage to the table or contents. If air is introduced into the system, the velocity fuse can lock up even though no failure has occurred. To reset the velocity fuse just activate pump by depressing the **UP** button. Remove the load and cycle the unit several times to purge air.

AIR BLEED PROCEDURE

If your unit descends very slowly or will not descend at all, air could be trapped in the hydraulic circuit and must be "bled" from the system. If you experience the above, follow these directions.

- 1.) Completely lower the platform and remove the load.
- 2.) Remove one cylinder from its mounting points.
- 3.) Rotate the cylinder so that the end with the pressure hose connection is "up" or is higher than any other point of the cylinder. This will allow the air to travel to a point in the cylinder where it can be expelled.
- 4.) Loosen the hose connection approximately 1/4 to 1/2 turn to allow trapped air to escape. *Using extreme caution*, you may need to "jog" the power unit slightly by quickly, momentarily depressing the UP button. Jogging the power unit will pressurize the hydraulic system, forcing trapped air from the cylinder.
- 5.) When the cylinder is free of air, tighten the hose connector fitting and reinstall the cylinder. Please note: The cylinder is now likely to be too long to fit into the original mounting points. To collapse the cylinder depress the DOWN button and manually force the cylinder back to its original length to install.
- 6.) Repeat procedure with other cylinder.

HYDRAULIC SCHEMATIC

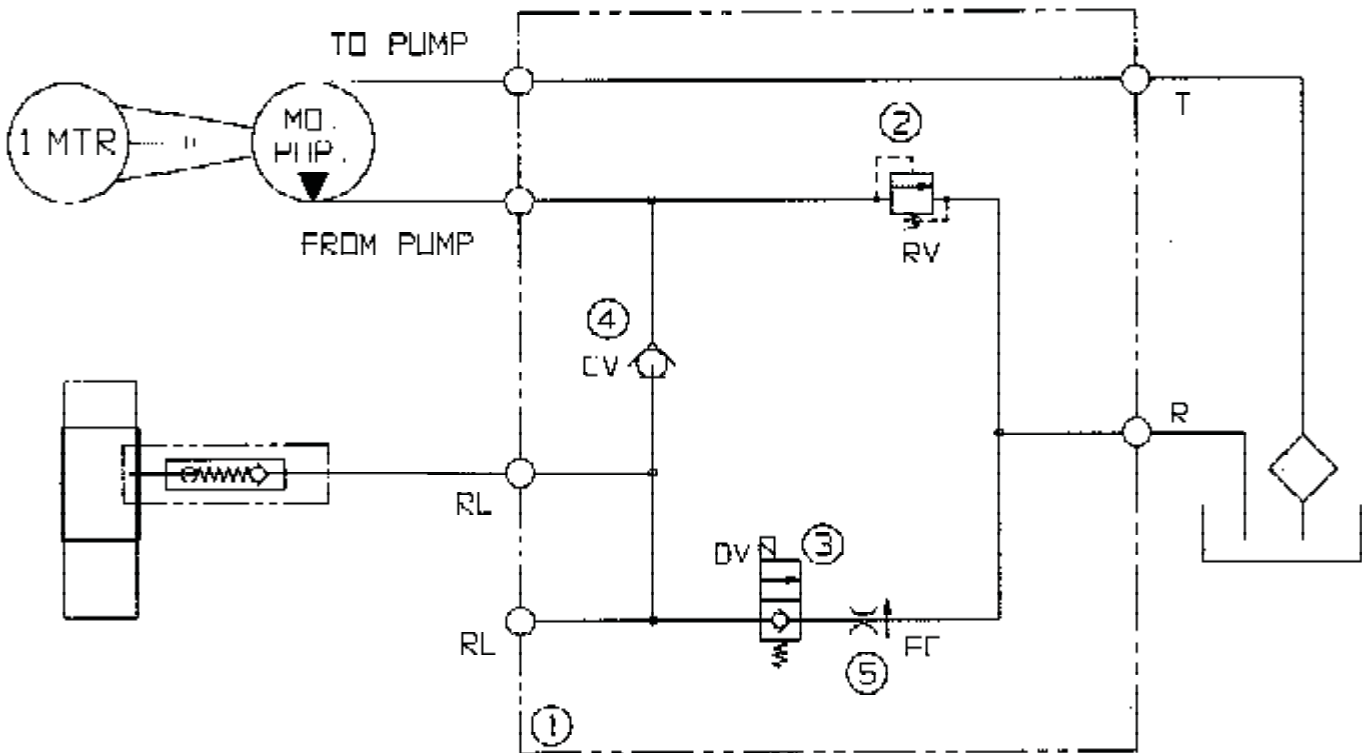

EXPLODED PARTS DRAWING
GROUND FILTER • BGLT-4000

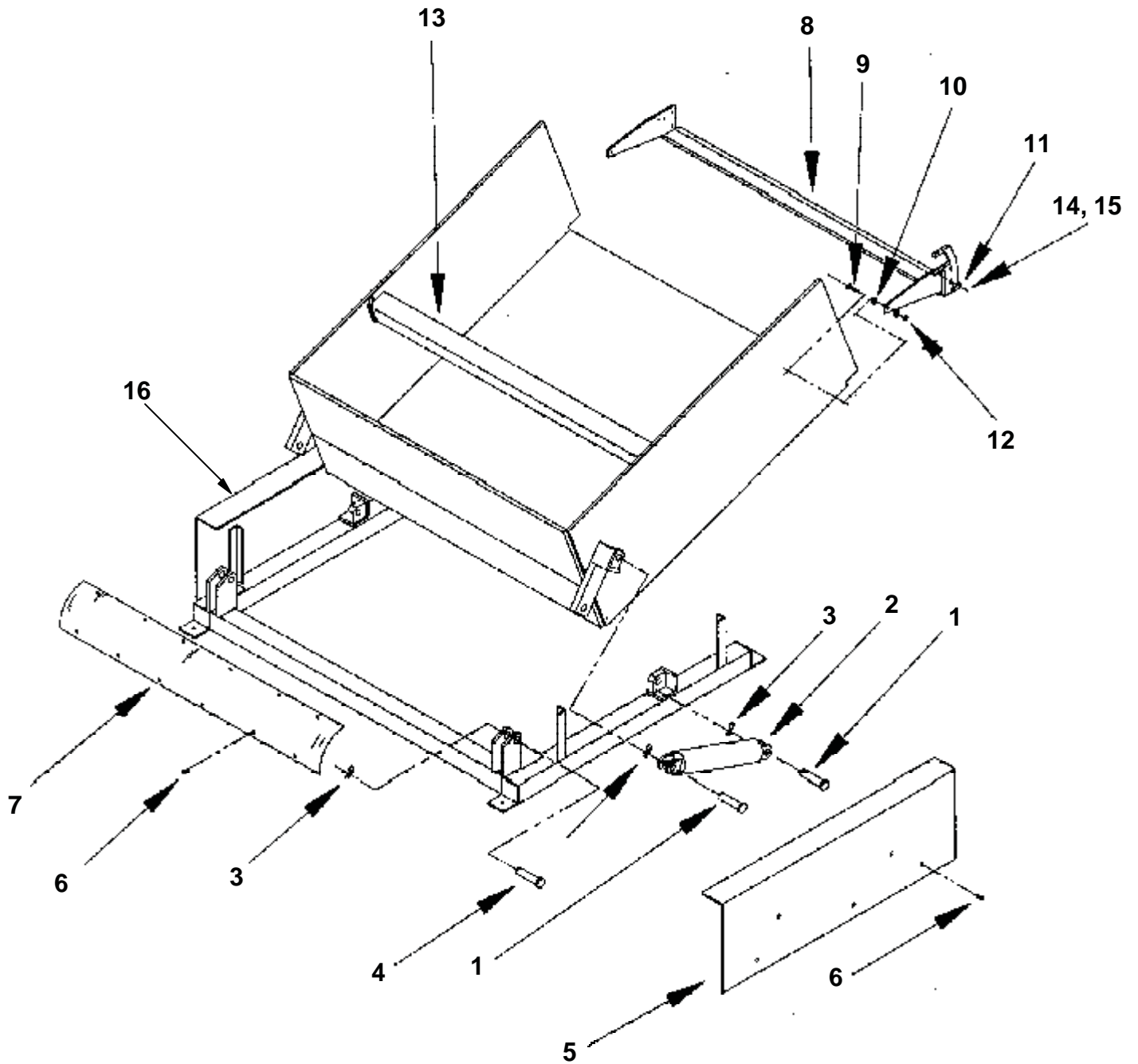

PARTS IDENTIFICATION
GROUND FILTER • BGLT-4000

ITEM NO.	DESCRIPTION	ENGINEER NO.	PART NO.	QTY
1	Clevis Pin 1 x 3-1/4	B2848	BGLT-CP-1	2
2	Cylinder 2 x 8	B04-021-004	BGLT-CYL	2
3	Hair Pin Clip	B45286	BGLT-HPC	6
4	Clevis Pin 1 x 2-1/4	B10-433-10	BGLT-CP-2	4
5	Right Side Guard	B04-024-016	BGLT-RSG	1
6	Screw 5-1/6-18 x 1/2 Self Tapping	B32416	BGLT-SC	12
7	Plastic Guard 12 x 51	BGLT-PLGD	BGLT-PLGD	1
8	Machiner Screw 5/16-18 x 1-1/4	B27745	BGLT-BLT-1	2
9	Toe Guard with Bevel	B04-015-029	BGLT-TG	1
10	Fender Washer 5/16	B33214	BGLT-WSR-1	4
11	Sensor Bracket	B04-016-021	BGLT-BKT	1
12	Lock Nut 5/16-18	B37021	BGLT-NUT-1	2
13	Cross Bar	B04-016-010	BGLT-CB	1
14	Toe Guard Bolt	B01-145-010	BGLT-TGB	4
15	Machine Screw 8-32 x 1/2	B24189	BGLT-MS	4
16	Left Side Guard	B04-024-017	BGLT-LSG	1
*17	Motor Pump Combo, 1 phz Low	BGLT-MPA-1A	BGLT-MPA-1A	-
*18	Motor Pump Combo, 1 phz High	BGLT-MPA-1B	BGLT-MPA-1B	-
*19	Motor Pump Combo, 3 phz Low	BGLT-MPA-3A	BGLT-MPA-3A	-
*20	Motor Pump Combo, 3 phz High	BGLT-MPA-3B	BGLT-MPA-3B	-
*21	Coil Only 24 vac.	B6316024	BGLT-CO	-
*22	Control Transformer	B01-129-001	BGLT-CT	-
*23	Cartridge Valve with Coil	BSV08-20-S-O-N-24AG	BGLT-CV-CO	-
*24	Cartridge Valve Only	BSV08-20-S-O-N	BGLT-CVO	-
*25	Dust Cover	BGLT-PU-DC	BGLT-PU-DC	-
*26	Foot Control	B01-522-012	BGLT-FC	-
*27	Hand Control	B01-522-015	BGLT-HC	-
*28	Hose Kit	BGLT-HK	BGLT-HK	-
*29	Junction Box	BAB-664JS	BGLT-JB	-
*30	Motor Contactor	BE9.10-24AC	BGLT-MC	-
*31	Single Phz. Motor Low Speed	B01-135-032	BGLT-MTR-1A	-
*32	Single Phz. Motor High Speed	B01-135-043	BGLT-MTR-1B	-
*33	Three Phz. Motor Low Speed	B01-135-029	BGLT-MTR-3A	-
*34	Three Phz. Motor High Speed	B01-135-030	BGLT-MTR-3B	-
*35	Pump 0.6 Disp.	B01-143-905	BGLT-PMP-0.06	-
*36	Pump 0.73 Disp.	B01-143-906	BGLT-PMP-0.73	-
*37	Pump 0.122 Disp.	B01-143-907	BGLT-PMP-0.122	-
*38	Pump 0.153 Disp.	B01-143-908	BGLT-PMP-0.153	-
*39	Reservoir Breather Cap	BGLT-PU-RBC	BGLT-PU-RBC	-
*40	Hydraulic Oil Reservoir	BGLT-PU-RES	BGLT-PU-RES	-

*Not shown in drawing

HYDRAULIC EQUIPMENT

Trouble Shooting Quick Reference Guide
(For further information contact the factory)

WARNING! BEFORE PERFORMING ANY MAINTENANCE WORK ALWAYS UNLOAD LIFT AND INSTALL MAINTENANCE SAFETY STOP(S)

Observation	Possible Cause	Remedy
1.) Table does not raise but pump is running or humming.	a. Motor may be single phasing (humming) if three phase unit.	a. Check wiring and overloads, fuses, etc. Ascertain that all 3 phase lines are present at the motor.
	b. Voltage at motor terminals may be too low to run pump at existing load.	b. Measure voltage at motor terminals or as near as possible, while pump is running under load. If voltage is sufficient, check for inadequate or incorrect wiring as this can starve the motor. (Refer to chart in Owner's Manual for recommendations.) Correct as necessary.
	c. Hose or hydraulic line is leaking.	c. Correct as necessary.
	d. Fluid level in reservoir is low.	d. Add fluid. Refer to Owner's Manual for proper fluid levels.
	e. Load exceeds capacity requirements. Relief Valve is bypassing the fluid back into the reservoir.	e. DO NOT CHANGE RELIEF VALVE SETTING. Instead, reduce the load to rated capacity.
	f. Suction filter is clogged, starving pump.	f. Remove and clean.
	g. Suction line may be leaking air, due to loose fittings.	g. Inspect all fittings for proper fit.
	h. Filler/Breather cap on tank may be clogged.	h. Remove and clean.
	i. Down Valve may be energized by faulty wiring or stuck open.	i. Remove Solenoid Valve. Check and clean. (Refer to Hydraulic Section of Owner's Manual p.10-11).
	j. Hydraulic pump may be inoperative.	j. Disconnect hydraulic line at power unit. Put pressure line in a large container and cycle pump. If no output, check the pump motor coupline, which may be defective, and correct as necessary. If pump is worn, consult factory for replacement parts service.
2.) Table raises too slowly.	a. Foreign material stuck in Down Solenoid, causing some fluid to bypass back into tank.	a. Lower the platform. Remove the Solenoid Valve and clean. (Refer to Hydraulic Section of Owner's Manual p. 10-11).
	b. Foreign material clogging suction filter, breather cap, or a pinched hose.	b. Correct as necessary. (See also, 1 (f), (h)).
	c. Low motor voltage.	c. See 1 (b).
	d. Table overloaded.	d. See 1 (e).
	e. Pump is inoperative.	e. See 1 (j).
3.) Motor labors, or is excessively hot.	a. Voltage may be low.	a. See 1 (b).
	b. Incorrect wiring.	b. Check that one leg of the motor lines is not connected to ground.
	c. Oil starvation causes pump to bind. High internal heat is developed. If this occurs, pump may be permanently damaged.	c. See 1 (d), (f), (g), (h), (j).
	d. Binding cylinders.	d. Align cylinders correctly.
4.) "Spongy" or "Jerky" table operation. Do not confuse spongy operation with small surges caused by foreign material on table wheel roller plate.	a. Fluid starvation.	a. See 1 (d), (f), (g), (j).
	b. Air in system.	b. See air bleed procedure p.9.

Observation	Possible Cause	Remedy
5.) Table lowers too slowly when loaded.	a. Down Valve filter clogged.	a. Remove Solenoid Valve and clean filter.
	b. Pinched tube or hose.	b. Correct as necessary. (In case of pipe, check for obstruction in line.)
	c. Foreign material in Flow Control Valve.	c. Remove and clean Flow Control Valve. (Refer to Hydraulic Section of Owner's Manual p. 10-11).
	d. Binding cylinders	d. Align cylinders correctly.
	e. Foreign material in Velocity Fuse.	e. Remove and clean Velocity Fuse. (Refer to Hydraulic Section of Owner's Manual p. 10-11).
6.) Table lowers too quickly.	a. Leaking hoses and/or cracked fittings.	a. Correct as necessary.
	b. Check valve is stuck open.	b. Remove and clean Check Valve. (Refer to Hydraulic Section of Owner's Manual p. 10-11).
	c. Foreign material stuck in Flow Control Valve. (In this case, table lowers initially at a normal rate then speeds up as the platform descends.)	c. Remove Flow Control Valve from the Valve Block and clean. (Refer to Hydraulic Section of Owner's Manual p. 10-11).
7. Table raises then lowers slowly.	a. Down Solenoid Valve may be incorrectly wired or is stuck open due to dirt.	a. See 2(a).
	b. Check Valve may be stuck open.	b. Remove and clean Check Valve. (Refer to Hydraulic Section of Owner's Manual p. 10-11).
	c. Check for leaking hoses, fittings, pipes.	c. Correct as necessary.
	d. Cylinder packings may be worn or damaged.	d. Replace packings. (Consult Factory for replacement parts.)
8. Table has raised, but does not lower.	a. Blown electrical fuse.	a. Check and replace.
	b. Incorrect Down Solenoid Valve wiring.	b. Correct as necessary. (Refer to Electrical Section of Owner's Manual.)
	c. Down Solenoid Valve is stuck.	c. Lightly tap down the Solenoid Coil body to seat it properly. (DO NOT hit coil hard as it will permanently damage the internal stem). DO NOT remove the Solenoid Valve from the Block as the unit will come down at a dangerous speed.
	d. Faulty Down Solenoid Coil.	d. Remove and replace. (Refer to Electrical Section of Owner's Manual.)
	e. Maintenance safety bar, or some other object blocking down travel.	e. Raise table and remove the safety bar, or whatever object is blocking the down travel, then press the down button.
	f. Binding cylinders.	f. See 2(e).
	g. In case of excessive down speeds, the Velocity Fuse will become operative and shut off the oil flow from the cylinders, thus the platform will remain stationary.	g. To unlock, re-pressurize the hydraulic system.
	h. Check if the Limit Switch is inoperative and the platform has raised all the way so that the mechanical stops are engaged. If mechanical stops are engaged, the Velocity Fuse has been locked up.	h. Refer to Velocity Fuse Section of the Owner's Manual p.8.

WARNING LABEL IDENTIFICATION

MAKE SURE ALL WARNING LABELS ARE IN PLACE!

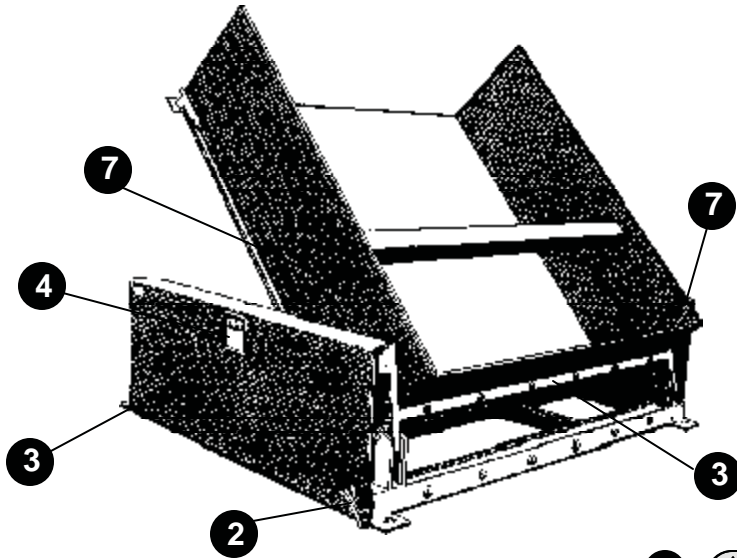

1

NOTICE	NOTA	AVIS
POWER SUPPLY: 115 Volt/1 Phase/60 HZ		
CONTROL VOLTAGE: 24 VOLT AC		
CORRIENTE: 115 Volt/1 Fase/60 HZ		
VOLTAJE DE CONTROL: 24 VOLT CA		
ALIMENTATION ÉLECTRIQUE: 115 Volt/1 Phase/ 60 HZ		
VOLTAGE DE CONTRÔLE: 24 VOLT AC		

248

2

⚠ WARNING	⚠ AVISO	⚠ AVERTISSEMENT
SECURE FRAME TO FLOOR	ASEGURE EL BASTIDOR AL PISO	FIXER SOLIDEMENT LE CADRE AU PLANCHER

204

3

⚠ WARNING	⚠ AVISO	⚠ AVERTISSEMENT
KEEP CLEAR WHEN IN USE	MANTENGASE ALEJADO CUANDO SE ESTA OPERANDO	SE TENIR À DISTANCE LORS DU FONCTIONNEMENT

220

4

⚠ WARNING	⚠ AVISO	⚠ AVERTISSEMENT
KEEP CLEAR OF PINCH POINT	MANTENGASE ALEJADO DE PUNTO DE CORTE	SE TENIR À DISTANCE DU POINT DE PINCEMENT

208

*Product safety signs or labels should be periodically inspected and cleaned by the product users as necessary to maintain good legibility for safe viewing distance . . . ANSI 535.4 (10.21)
Contact manufacturer for replacement labels if needed.

5 ON HYDRAULIC TANK (NOT SHOWN)

ISO AW-32	
HYDRAULIC OIL OR EQUIVALENT	
ACEITE HIDRÁULICO O EQUIVALENTE	
HYDRAULIQUE OU ÉQUIVALENT	

206

6

DANGER ⚠	SHUT POWER OFF AND CONSULT OWNERS MANUAL BEFORE WORKING ON THIS EQUIPMENT
PELIGRO ⚠	CORTE LA CONSULTA Y CONSULTE EL MANUAL DEL PROPIETARIO ANTES DE TRABAJAR EN ESTE EQUIPO
DANGER ⚠	COUPER LE COURANT ET CONSULTER LE MANUEL D'UTILISATION AVANT DE TRAVAILLER SUR CET ÉQUIPEMENT

221

7

<p>⚠ DANGER</p> <p>⚠ PELIGRO</p> <p>⚠ ATTENTION</p>	<p>TO AVOID PERSONAL INJURY READ OWNER'S MANUAL BEFORE OPERATING OR REPAIRING SCISSOR LIFT</p> <p>PARA EVITAR DAÑOS PERSONALES LEA EL MANUAL DEL PROPIETARIO ANTES DE OPERAR O REPARAR EL ELEVADOR DE TIJERAS</p> <p>POUR ÉVITER TOUTE BLESSURE PERSONNELLE LIRE LE MANUEL DU PROPRIÉTAIRE AVANT DE METTRE EN MARCHÉ OU AVANT DE RÉPARER L'ÉLEVATEUR CISEAU</p>	<p>DO NOT PUT HANDS, FEET OR OBJECTS UNDER TOP. LOWER PLATFORM SLOWLY.</p> <p>NO PONGA MANOS, PIES U OBJETOS DEBAJO DEL BORDE DESCRIENDO LA PLATAFORMA LENTAMENTE.</p> <p>NE PAS METTRE LES MAINS, LES PIEDS OU TOUT OBJET SOUS LE PLATEAU SUPÉRIEUR. DESCENDRE LA PLATFORME LENTEMENT</p>	<p>DO NOT WORK UNDER LIFT WITHOUT SAFETY BLOCK OR WHILE LOADED. KEEP CLEAR OF MOVING SCISSOR LEG MECHANISM.</p> <p>NO TRABAJE DEBAJO DEL ELEVADOR SIN LOS FRENOS DE SEGURIDAD O CUANDO ESTÉ CARGADO. MANTENGASE ALEJADO DEL MECANISMO DE TIJERA EN MOVIMIENTO.</p> <p>NE PAS TRAVAILLER SOUS L'ÉLEVATEUR SANS BLOCS DE SÉCURITÉ OU LORSQU'IL EST CHARGÉ. RESTER À L'ÉCART DU MÉCANISME CISEAU LORSQUE L'ÉLEVATEUR EST EN FONCTIONNEMENT.</p>	<p>DO NOT STAND, SIT OR RIDE ON LIFT</p> <p>NO SE SIENTE, SE PARE O VIAJE EN EL ELEVADOR</p> <p>NE PAS SE TENIR DEBOUT, S'ASSEOIR OU MONTER SUR L'ÉLEVATEUR</p>
--	---	--	--	---

207

LIMITED WARRANTY

ONE YEAR LIMITED WARRANTY. The manufacturer warrants for the original purchaser against defects in materials and workmanship under normal use one year after date of purchase. (Not to exceed 15 months after date of manufacture.) Any part which is determined by the manufacturer to be defective in material or workmanship and returned to the factory, shipping costs prepaid, will be, as the exclusive remedy, repaired or replaced at our option. Labor costs for warranty repairs and/or modifications are not covered unless done at manufacturer's facilities. Any modifications performed without written approval of the manufacturer may void warranty. This limited warranty gives purchaser specific legal rights which vary from state to state.

LIMITATION OF LIABILITY. To the extent allowable under applicable law, the manufacturer's liability for consequential and incidental damages is expressly disclaimed. The manufacturer's liability in any event is limited to, and shall not exceed, the purchase price paid. Misuse or modification may void warranty.

WARRANTY DISCLAIMER. Our company has made a diligent effort to illustrate and describe the products shown accurately; however, such illustrations and descriptions are for the sole purpose of identification, and do not express or imply a warranty that the products are merchantable, or fit for a particular purpose, or that the products will necessarily conform to the illustrations or descriptions.

The provisions of the warranty shall be construed and enforced in accordance with the UNIFORM COMMERCIAL CODE and laws as enacted in the State of Indiana.

DISPOSITION. Our company will make a good faith effort for prompt correction or other adjustment with respect to any product which proves to be defective within the Limited Warranty. Warranty claims must be made in writing within said year.

SERVICE RECORD

DATE OF SERVICE: ____/____/____
WORK DONE BY: _____
SERVICE PERFORMED: _____

DATE OF SERVICE: ____/____/____
WORK DONE BY: _____
SERVICE PERFORMED: _____

DATE OF SERVICE: ____/____/____
WORK DONE BY: _____
SERVICE PERFORMED: _____

DATE OF SERVICE: ____/____/____
WORK DONE BY: _____
SERVICE PERFORMED: _____

DATE OF SERVICE: ____/____/____
WORK DONE BY: _____
SERVICE PERFORMED: _____

DATE OF SERVICE: ____/____/____
WORK DONE BY: _____
SERVICE PERFORMED: _____

